

LOC		DIST		P		F		ZONE		LTR		REVISIONS	
DESCRIPTION	DATE	APPD											
AJ	16											R	0BS -34 PER 0U20-0076-01
													26FEB01 MO

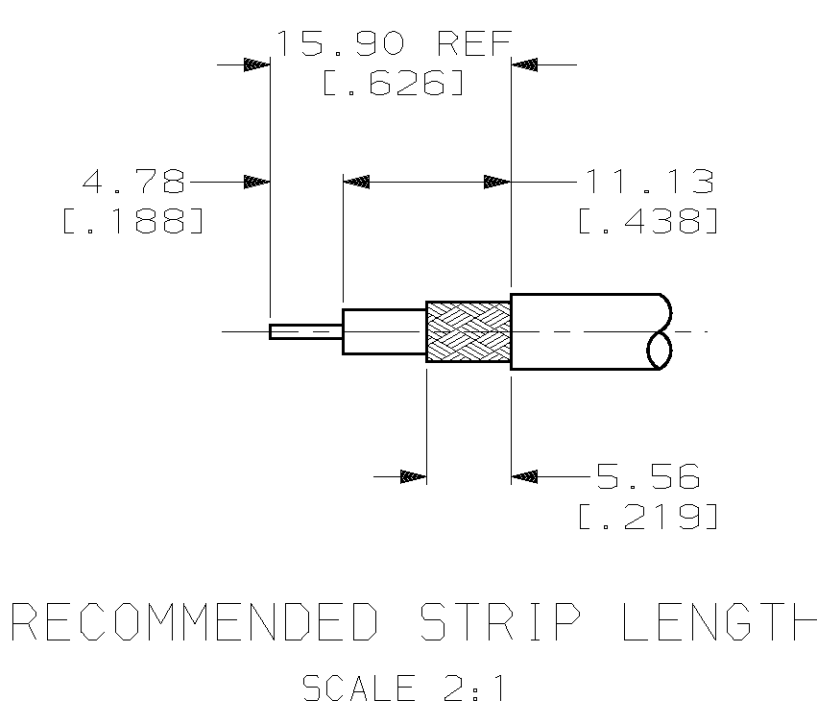
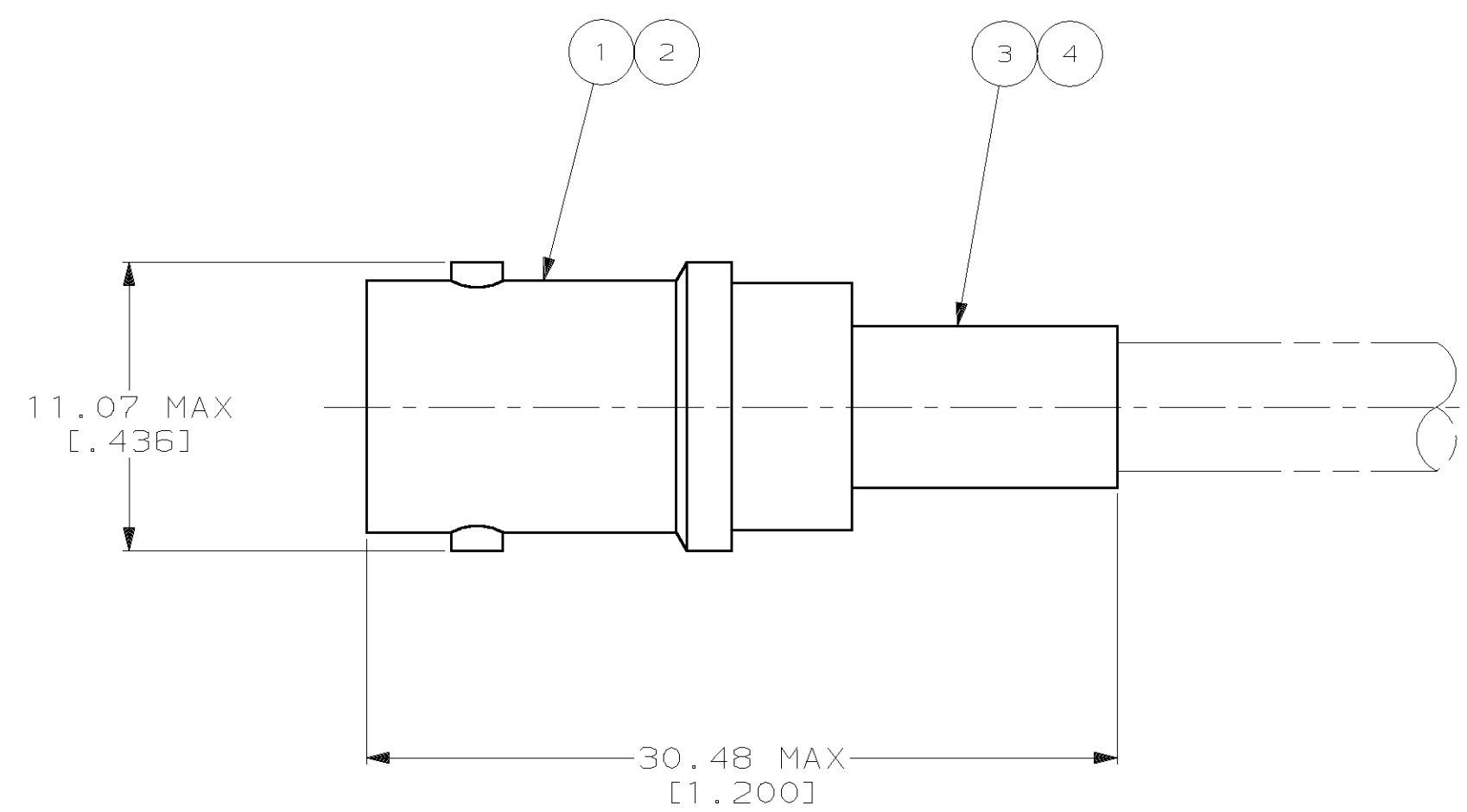

[OBSOLETE]	AMP & 3-331351-4	ITT-3474	220029-1	-	50428-1	225136-3	331355	3-331351-4
SUPERSEDED BY 2-329452-2	00779-M39012/17B0007 YY WW	RG-142/U, 142A/U & 142B/U	69478-1	-	329099	2-331369-4	2-331355-1	2-331351-9
SUPERSEDED BY 2-225396-1	00779-M39012/17B0006 YY WW	RG-141/U & 141A/U	69478-1	-	50427-1	2-331369-4	2-331355-1	2-331351-8
[OBSOLETE]	00779-M39012/17B0005 YY WW	RG-55/U, 55A/U, 55B/U & 223/U	69478-1	-	329099	2-331369-3	2-331355-1	2-331351-7
SUPERSEDED BY 225396-9	AMP & 2-331351-6	RG-180/U, 180A/U & 195/U	69477-2	-	329461	1-331368-4	2-331355-2	2-331351-6
SUPERSEDED BY 225396-8	AMP & 2-331351-5	RG-179/U & 187/U	220009-1	21427-2	2-328666-3	1-331368-4	2-331355-2	2-331351-5
	AMP & 2-331351-4	RG-174/U & 188/U	220009-1	21427-2	2-328666-3	1-331368-2	2-331355-2	2-331351-4
[OBSOLETE]	AMP & 2-331351-2	AMPHENOL 21-597	69477-2	-	329461	1-331368-2	2-331355-2	2-332351-2
	00779-M39012/17B0004 YY WW	RG-58/U, 58A/U, 58B/U & 58C/U	69478-1	-	50427-1	2-331369-3	2-331355-1	2-331351-1
	00779-M39012/17B0008 YY WW	RG-59/U, 59A/U, 59B/U, 62/U, 62A/U & 62B/U	69477-1	-	50428-1	3-331368-9	331355	331351
	STAMPING	CABLE SIZE	CRIMP TOOL	④ BUSHING QTY=1	③ FERRULE QTY=1	② CONTACT QTY=1	① JACK ASSY QTY=1	PART NUMBER

PART NO		NAME	
DO NOT SCALE PRINT. UNLESS SPECIFIED DIMENSIONS IN mm [INCHES] TOLERANCES ON: 2 PLC DEC ± 0.41 [0.016] 3 PLC DEC ± - ANGLES ± -	DR 2-15-91 B. SCOTT	AMP Incorporated Harrisburg, PA 17105-3508	
MATERIAL	CHK 3-18-91 J. LIPPERT	JACK, DUAL CRIMP, SERIES BNC	
FINISH	APPD 4-3-91 M. PHILLIPS	SIZE D	CAGE CODE 00779
	APPD 4-3-91 J. LIPPERT	DRAWING NO	331351
	PRODUCT SPEC 108-12020	SCALE	4:1
	APPLICATION SPEC	SHEET	1 OF 1
	WEIGHT	CUSTOMER DRAWING	